

stryker

GMRS[®] Proximal Tibia

Global Modular
Replacement System



Surgical protocol

GMRS Proximal Tibia surgical protocol

GMRS Proximal Tibia

Surgical protocol

Contents

Introduction	2
Description of the Global Modular Replacement System Proximal Tibia	4
Indications/contraindications	6
Surgical protocol	7
Measuring resection length	8
Tibial osteotomy	9
Femoral sizing	9
Preparation for the MRH femoral component	10
Femoral canal preparation	10
Distal femoral resection	11
Intramedullary alignment	12
Femoral sizing and resection	12
Femoral Trial positioning	14
Preparation of the tibia	15
Trial assembly	15
Trial reduction	16
Tibial implant assembly	17
Femoral implant assembly	18
Implantation and orientation of the femoral and tibial prostheses	19
Final trial articulation with prostheses	20
Assembly of rotating hinge mechanism	20
Appendix- taper disassembly	23
Implant listing and resection length overview chart	25

Introduction

The GMRS Standard Proximal Tibia accepts the Modular Rotating Hinge (MRH) resurfacing hinge.

The GMRS Proximal Tibia is available in two sizes, standard and small.

The GMRS family of cemented stems offers two types: with or without extra-cortical porous-coated body sections.



Description of the Global Modular Replacement System Proximal Tibia

The GMRS System is designed to:

- Reconstruct large segmental defects of the proximal tibia.
- Reconstruct osteoarticular defects of varying sizes.
- Allow for variation and intra-operative changes of the surgical plan.

The system consists of proximal tibial components, tibial inserts, tibial sleeve, extension pieces and stems.

The modular implants utilize a male/female taper locking mechanism. The components are assembled during surgery by impacting them together. The impaction causes the taper to securely lock the components together.

Tibial components

The proximal tibial components have a replacement length of 80mm, measured to the sulcus of the thinnest, 10mm, tibial insert.

Note: The Global Modular Replacement System Standard Proximal Tibial Component (6495-3-102) accepts the Modular Rotating Hinge (MRH) Tibial Inserts. The Small Proximal Tibial Component (6495-3-101) accepts the Small GMRS Tibial Inserts (6495-3-0xx) and the Small GMRS Tibial Rotating Component (6495-3-601).





MRS cemented stems

Diameter	Cemented straight stems	Cemented straight stems with body
Ø8mm	6485-3-018	6485-3-008
Ø9mm	6485-3-019	6485-3-009
Ø10mm	6485-3-010	6485-3-000
Ø11mm	6485-3-111	6485-3-011
Ø13mm	6485-3-113	6485-3-013
Ø15mm	6485-3-115	6485-3-015
Ø17mm	6485-3-117	6485-3-017

The GMRS Proximal Tibia accepts the modular cemented stems, available with or without a 40mm extra cortical porous body section. Optional stem centralizers are available for the 10-17mm diameter stems.



Extension Pieces

The Extension Pieces are used to customize the replacement length and are available in 30mm, 40mm, 50mm, 60mm, 70mm, 80mm, 100mm, 120mm, 140mm, 160mm, 180mm, 200mm and 220mm lengths.



MRH femoral components

The MRH femoral components are available in 5 sizes: X-SML, SML, MED, LRG, X-LRG in left and right configurations. These femoral components require a 9mm resection of the distal femur.

Indications

The Global Modular Replacement System is intended for use in patients requiring extensive reconstruction of the hip joint and/or knee joint, including knee fusions, necessitated by extensive bone loss due to trauma, failed previous prosthesis and/or tumor resection.

Contraindications

A. As related to bone tumors:

Not all bone tumors may be treated successfully by segmental resection. Any condition that may have already resulted in either local or distant spread of the tumor may be a contraindication. Examples of such conditions include:

- Pathological fracture;
- Overt infection;
- Inopportune placement of biopsy incision; and,
- Rapid disease progression beyond a respectable margin.

Each patient must therefore be individualized and carefully evaluated by appropriate staging techniques prior to consideration of segmental replacement.

B. As related to failed previous prosthesis and trauma:

- Any active or suspected latent infection in or about the operative joint.
- Any mental or neuromuscular disorder which would create an unacceptable risk of prosthesis instability, prosthesis fixation failure, or complication in postoperative care.
- Bone stock compromised by disease, infection, or prior implantation, which cannot provide adequate support and fixation of the prosthesis.
- HA coated stems are contraindicated in situations where bone stock is inadequate to support press fit application.

See package insert for warnings, precautions, adverse effects, information for patients, and other essential product information.

Before using GMRS instrumentation, verify:

- Instruments have been properly disassembled prior to cleaning and sterilization;
- Instruments have been properly assembled post-sterilization;
- Instruments have maintained design integrity; and,
- Proper size configurations are available.

For Instructions for Cleaning, Sterilization, Inspection and Maintenance of Orthopaedic Medical Devices, refer to LSTPI-B.

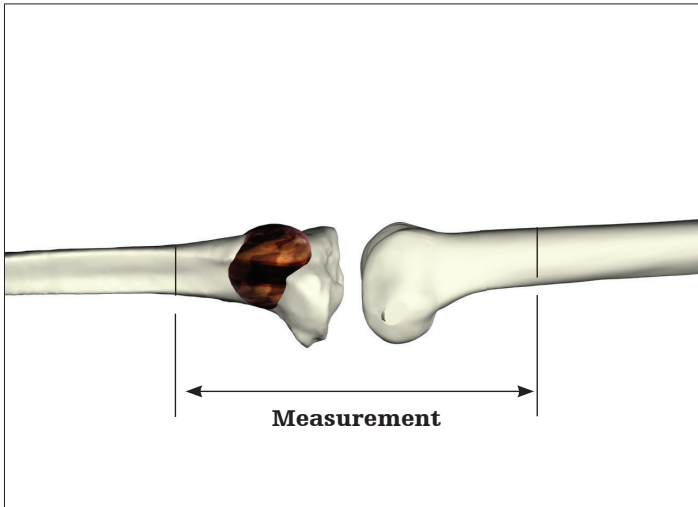

Figure 1

Measuring resection length

The Proximal Tibial Template may be used as a guide to determine resection location. The template can be positioned using either of two methods.

First, the proximal straight edge, engraved 'Distal Femoral Cut', can be positioned 9mm proximal to the distal most aspect of the condyles and determining the resection location from the appropriate slot (**Figure 2**).

Second, the profile of the outline of the implant condyles on the template can be aligned with the distal most aspect of the condyles by viewing them through the medial and lateral cut outs in the template (**Figure 2 inset**) and determining the resection location from the appropriate slot. Resection lengths indicated in the template are based on a 10mm insert and include the tibial bearing component length.

The minimum resection of the tibia is 99mm, which includes 8mm for the tibial bearing component, 80mm from the proximal tibial component with 10mm insert, and a bodiless stem (11mm replacement length).

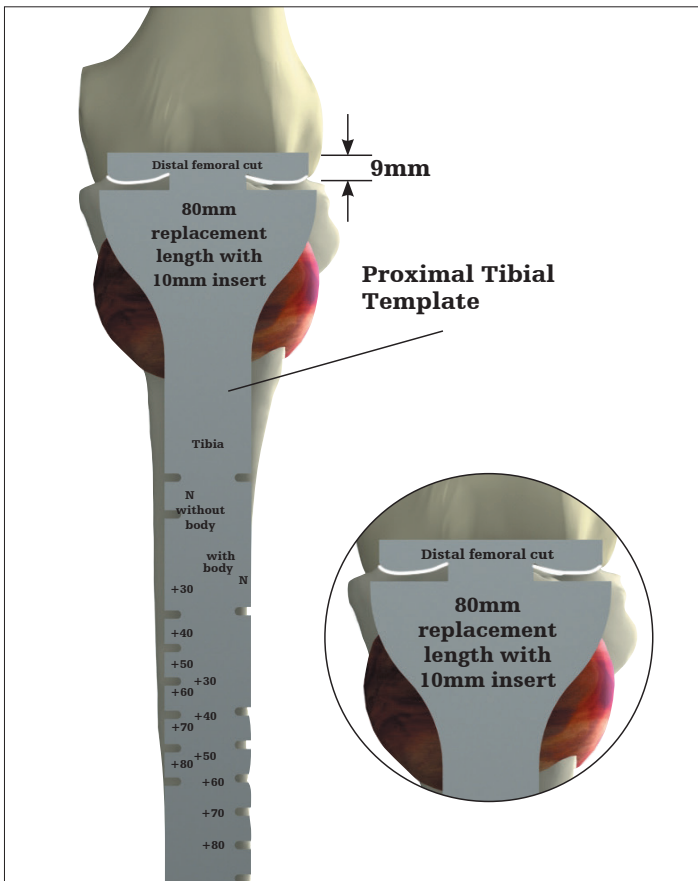

Figure 2

6496-9-072
 Proximal Tibial Template
 GMRS Tray No: 2

Note: Frame color around each instrument indicates the corresponding GMRS Instrument Tray color.

Instruments without a colored frame are instruments from the MRH or the Duracon TS Instrument Trays.

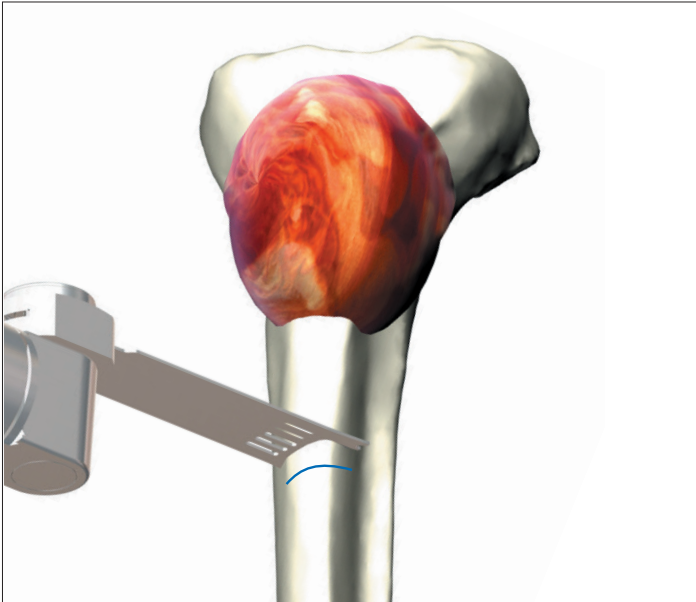

Figure 3

Tibial osteotomy

All remaining soft tissue at the level of transection is cleared. The osteotomy, perpendicular to the tibial shaft, is performed after the surrounding tissues and structures have been protected and retracted (**Figure 3**).

Surgical tip: Resect the tibia slightly proximal to the marked resection level to allow the facing reamer (see Figure 13 page 15) to plane accurately up to the mark at a 90° angle.

Note: It is extremely important not to distract the extremity following the resection to protect the neurovascular structures. The end of the tibial osteotomy should be kept well padded to avoid injuring the vessels. The length of the resected specimen should be checked and measured again following resection.

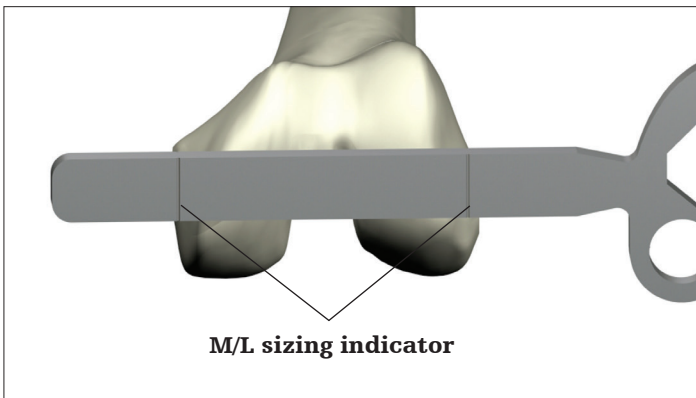

Figure 4a

Femoral sizing

In addition to pre-operative templating, femoral sizing may be established using the Femoral Sizing Template. The Femoral Sizing Template may be used to evaluate the M/L width of distal femur (Figure 4a) or by evaluating the position of the anterior flange cut with respect to the IM canal (**Figure 4b**).

If the two sizing methods differ, the smaller femoral size should be selected assuming that the smaller component will not notch the femur.

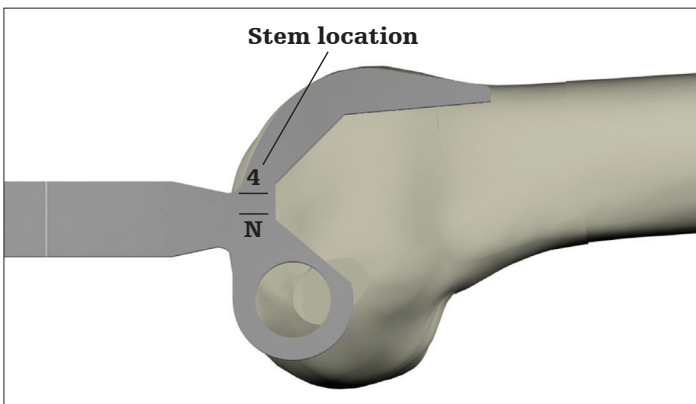

Figure 4b

6481-1-02X

Femoral Sizing
Template

MRH Instrument Tray H2



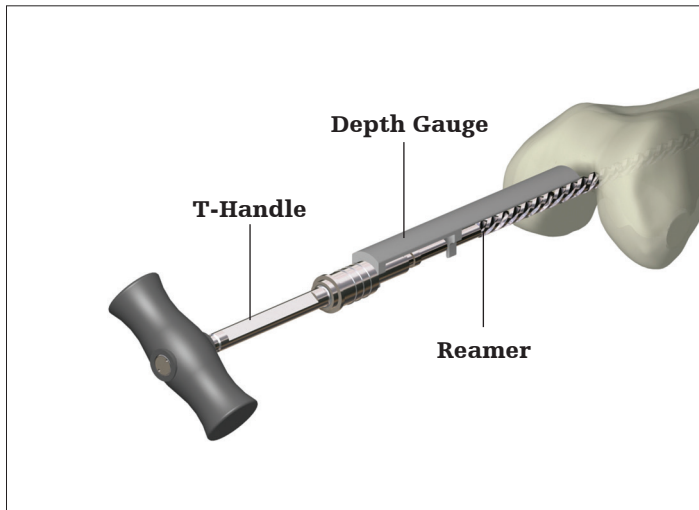

Figure 5

Femoral preparation for the Modular Rotating Hinge (MRH) femoral component

Femoral canal preparation

The Intracondylar Starter Drill should be used to create a hole immediately anterior to the insertion of the anterior cruciate ligament. A stem of at least 80mm must be used on the MRH femoral components. IM Reamers, available in diameters 8–23mm, are sequentially advanced into the canal until the tip of the appropriate Depth Gauge reaches the level of the most prominent bony aspect of the distal femur (Figure 5).

Note: It is extremely important not to distract the extremity following the resection to protect the neurovascular structures. The end of the tibial osteotomy should be kept well padded to avoid injuring the vessels. The length of the resected specimen should be checked and measured again following resection.

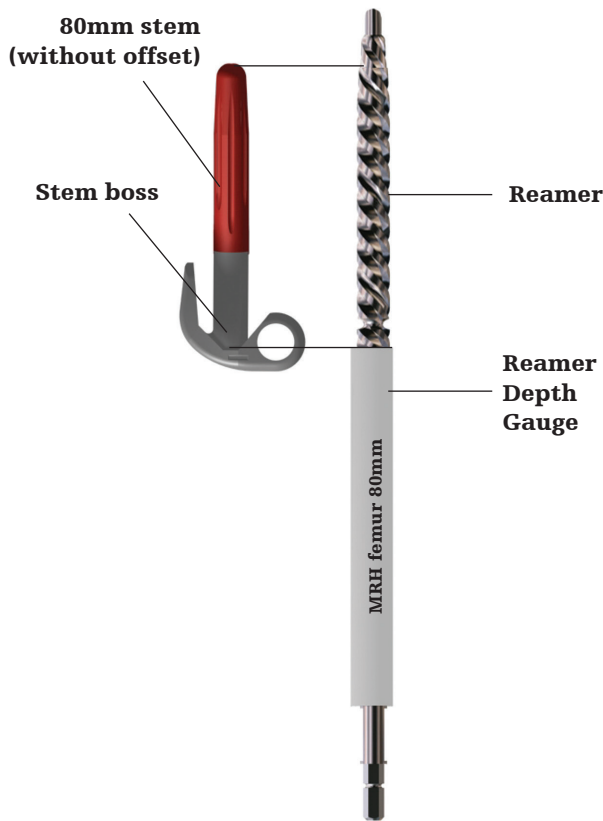

Figure 6

Figure 6 gives an example of depth stops marking, and how it relates to preparation of the medullary canal for a given combination of implants. The reamers prepare the canal for a line-to-line fit for the Cobalt Chrome Stems and prepare the canal for a 1/2mm interference fit for the Titanium Fluted Stems.

Surgical tip: In situations where stem diameters of 14mm or less are being used, it is necessary to ream the medullary canal of the distal femur with a 15mm reamer to at least 52mm. This reaming provides the necessary clearance to fully seat the cutting guide instrument and the “stem boss” portion of the stemmed femoral component.

It is strongly recommended that the intramedullary reaming be performed manually to avoid bone perforation and/or fracture.

6838-7-673

Intracondylar Starter Drill



IM Reamer Tray R2

6633-9-4XX

IM-Reamer



IM Reamer Tray R2

6266-5-410

T-Handle



IM Reamer Tray R2

6481-1-05X

IM-Reamer
Depth Gauge



MRH Instrument Tray H2

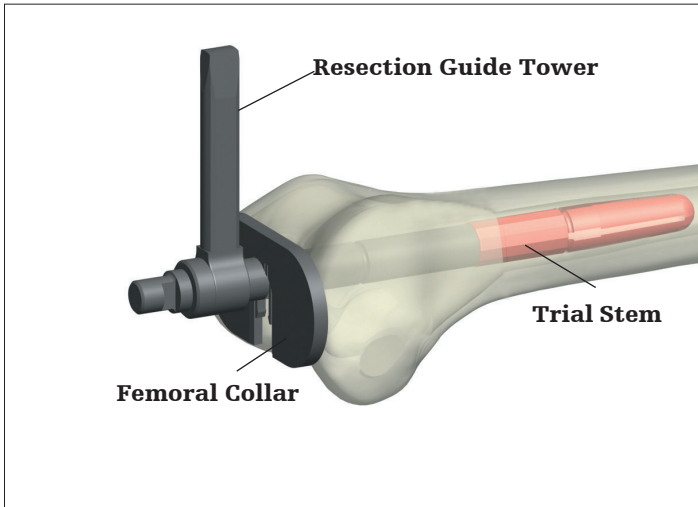

Figure 6a

Distal femoral resection

After preparing the medullary canal, the corresponding diameter Trial Stem is selected and attached to the Resection Guide Tower. The appropriate left or right Femoral Collar may be attached to the tower to assist in setting the final depth and rotation of the instrument (Figure 6a). The assembly is inserted into the canal until the collar contacts the most prominent bony aspect of the distal femur.

Surgical tip: To insert and extract the assembly in and out of the medullary canal, the T-Handle and Impactor/Extractor can be utilized (Figure 6b).

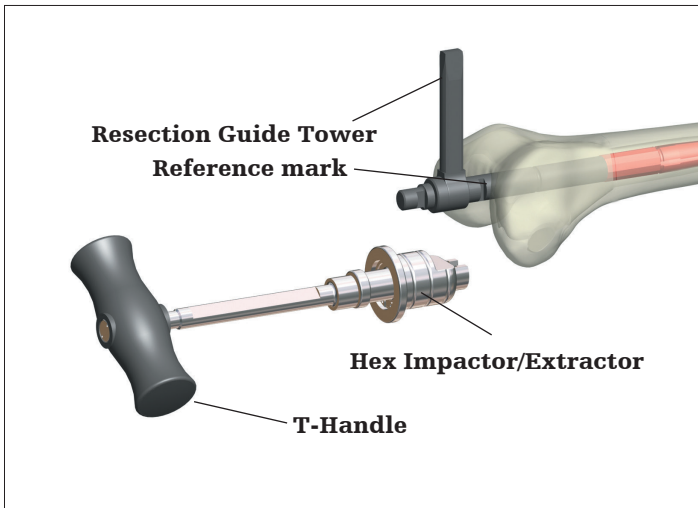

Figure 6b

6778-6-XXX

Trial Stem



Trial Stem Tray R6

6633-9-428

Resection Guide Tower



Extension Gap Prep. Tray R3

6633-9-48X

Femoral Collar



Extension Gap Prep. Tray R3

6633-9-404

Impactor/Extractor



Extension Gap Prep. Tray R3

6633-9-430

Femoral Resection Guide



Extension Gap Prep. Tray R3

6838-7-2X0

Alignment Rod



Extension Gap Prep. Tray R3

6633-7-250

Alignment Handle



Extension Gap Prep. Tray R3

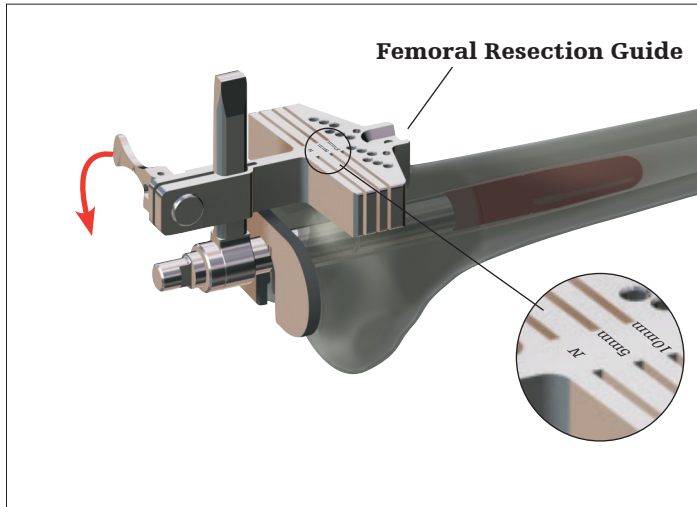

Figure 7a

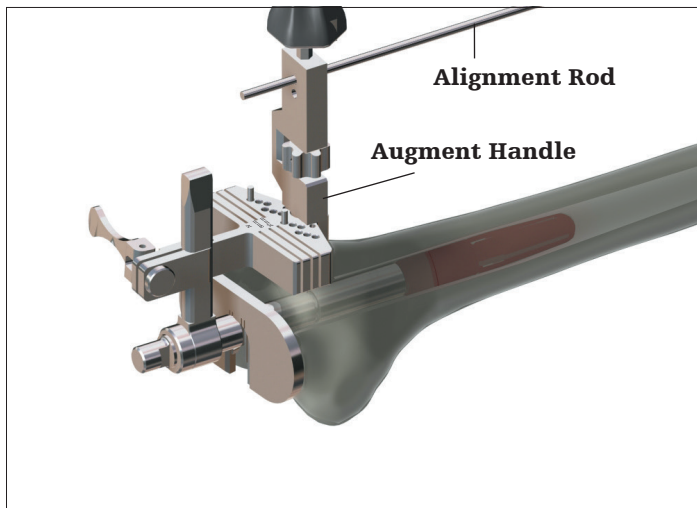

Figure 7b

The 6° valgus Femoral Resection Guide is assembled to the resection guide tower such that the appropriate left or right marking is visible and slid down to touch the anterior femur and secured using the cam-lock mechanism (**Figure 7a**). Further fixation to the femur can be achieved by adding 1/8" (3.2mm) Drills or pins through the Femoral Resection Guide.

With the Femoral Resection Guide pinned in place, the cam-lock mechanism is released and the resection guide tower with the trial stem are removed. An additional drill pin is then inserted obliquely into the "X" drill hole to further stabilize the guide.

For an intact femur, the distal cut is performed through the "10mm" slot. For a revision, a 2mm "clean up" cut is performed through the slot marked "N" for neutral and the "10mm" slot can be used to prepare for a 10mm distal femoral augment, if required.

Note: If a further resection is required, the cutting guide can be re-positioned referencing the pins placed on the distal femur through the 2mm or 4mm pinholes on the resection guide. If this is done, the medullary canal should be reamed a further 2mm or 4mm in order to ensure the implant is fully seated.

Surgical tip: Before fixing the resection guide with 1/8" drills, alignment can be verified by referencing the position of the femoral head with the Alignment Rod inserted through the "NF" hole on the Alignment Handle, attached to the Distal Femoral Resection Guide (Figure 7b).

Intramedullary alignment

The appropriate left or right 6° Valgus Stem Adaptor is assembled to the selected size Femoral A/P Chamfer Resection Guide and set to the “N” line on the resection block. The Trial Stem is then attached (**Figure 8a**). The assembly is inserted into the canal until the Resection Guide rests against the cut distal femur (**Figure 8b**).

If a 10mm distal augment cut has been made for a femur being revised, a magnetic 10mm Resection Guide Spacer may be attached to the Femoral Resection Guide (**Figure 8c**).

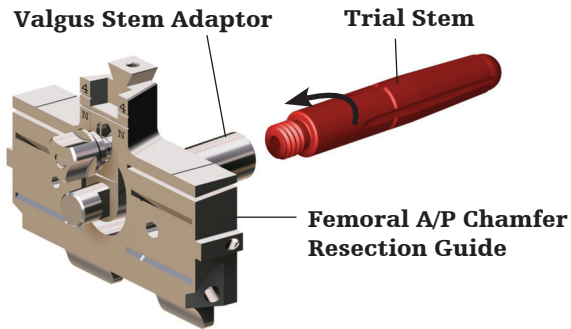

Figure 8a

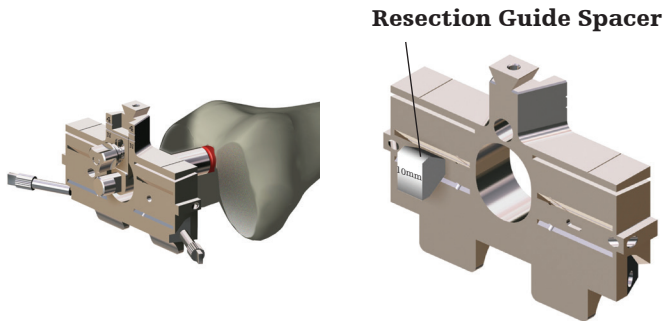

Figure 8b

Figure 8c

6633-9-46X

Valgus Stem Adaptor

MRH Instrument Tray H2

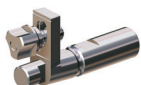

6481-1-01X

Femoral A/P Chamfer Resection Guide

MRH Instrument Tray H2



6481-1-009

Resection Guide Spacer

MRH Instrument Tray H2



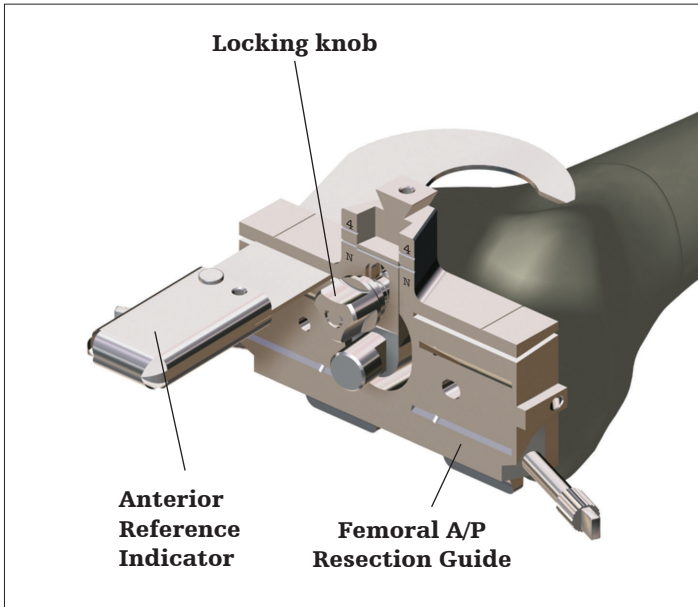

Figure 9

Femoral sizing and resection

Femoral sizing can be verified using the Anterior Reference Indicator referencing the anterior cortex (**Figure 9**).

Correct internal/external rotation of the Femoral A/P Chamfer Resection Guide can be achieved by setting the Guide parallel to the transepicondylar axis. The guide can then be fixed using 1/8" (3.2mm) Drills or pins.

Surgical tip: The tabs on the posterior aspect of the Femoral A/P Chamfer Resection Guide represent the posterior condyles of the Femoral Component.

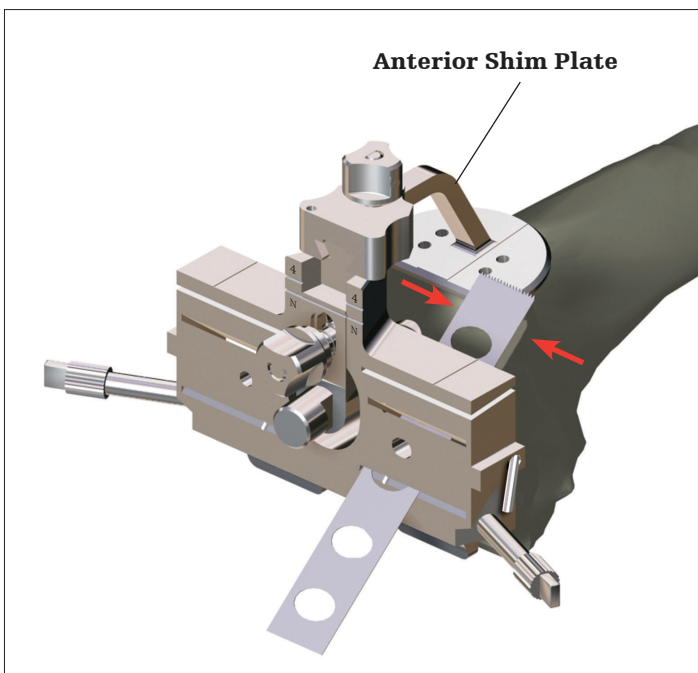

Figure 10

After making the anterior flange resection, the Anterior Shim Plate can be attached to the Femoral A/P Chamfer Resection Guide to provide stability for the Resection Guide Assembly during the anterior and posterior chamfer resections (**Figure 10**).

Surgical tip: A narrow oscillating saw blade of approximately 1/2" (12.7mm) is recommended for the chamfer cuts.

6633-9-464

Anterior Shim Plate

MRH Instrument Tray H2



6633-8-052

Anterior Reference Indicator

MRH Instrument Tray H2



Femoral Trial positioning

The Trial Femoral Component can be fitted with the appropriate Trial Stem before being placed onto the prepared bone (**Figure 11**).

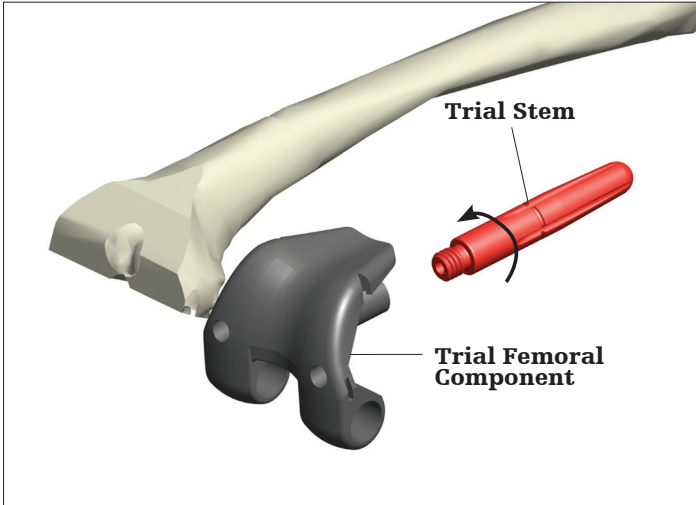

Figure 11

6481-1-3XX

Trial Femoral Component

MRH Instrument Tray H1



6778-6-XXX

Trial Stem

Trial Stem Tray R6

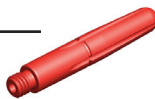

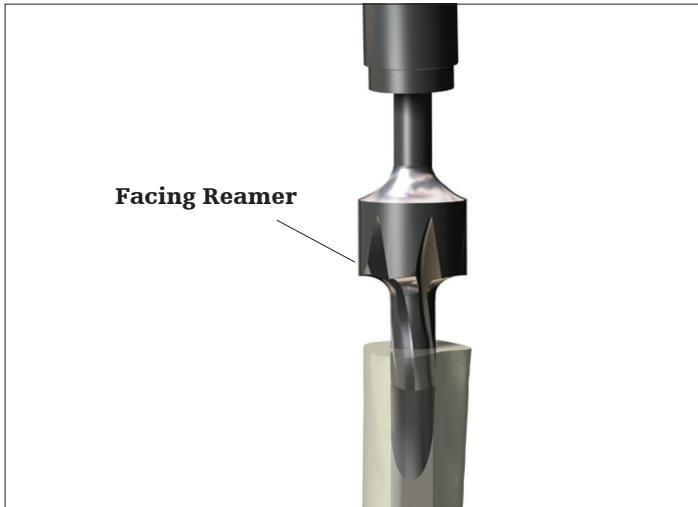

Figure 12

Preparation of the tibia

A flexible guide wire is inserted into the tibial canal. Flexible reamers are utilized to progressively ream the canal to the appropriate diameter. To permit an adequate cement mantle, a stem 2mm smaller than the final reamer diameter should be selected.

Note: The seven stem diameters are 8mm, 9mm, 10mm, 11mm, 13mm, 15mm, and 17mm.

The appropriate Facing Reamer is used to plane the osteotomy site to ensure direct contact and accurate seating of the prosthesis by preparing for the radius at the stem/seat junction (**Figure 12**).

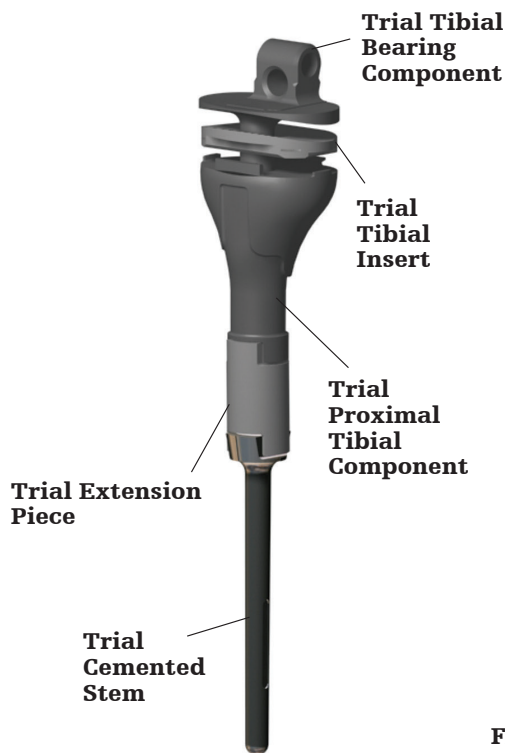



Figure 13

Trial assembly

Construct the Trial Tibial Prosthesis by joining the Trial Stem with the Trial Proximal Tibia Component, and Trial Extension Piece, if necessary. The Trial Insert is seated onto the trial proximal tibial component and the Trial Tibial Bearing Component is inserted through the trial insert into the Trial Proximal Tibia Component (**Figure 13**).

6496-9-2XX
Facing Reamer
GMRS Tray No: 4A



6486-3-XXX
Trial Stem
GMRS Tray No: 4A



6496-3-10X
Trial Proximal Tibial Component
GMRS Tray No: 2



6496-6-0X0
Trial Extension Piece
GMRS Tray No: 2



6481-3-5XX
6496-3-0XX
Trial Inserts
GMRS Tray No: 2

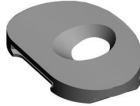

6496-3-60X
Trial Tibial Bearing Component
GMRS Tray No: 2



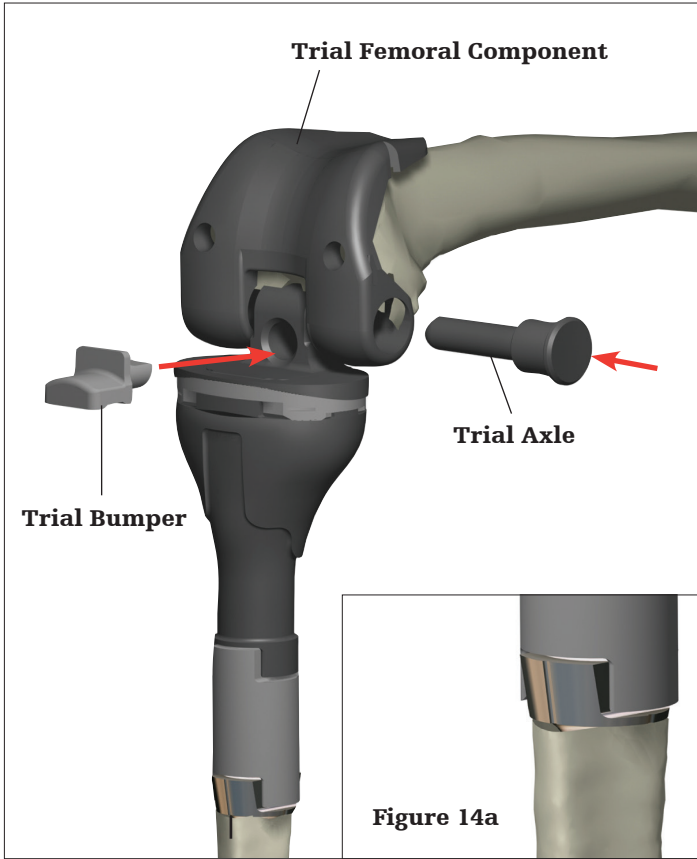

Figure 14

Trial reduction

Insert the trial tibial component construct into the tibia until it is flush with the osteotomy. Insert the Trial Femoral Component construct into the femur until it is flush with the cut surfaces.

Line up the Trial Tibial Bearing Component with the holes of the Trial Femoral Component and slide the Trial Axle into the assembly. Insert the Trial Bumper into the Trial Tibial Rotating Component (**Figure 14**).

Note: The Trial Bumper is available in two configurations, neutral and 3° flexion.

The purpose of the trial reduction is to determine the ease of insertion of the femoral and tibial components prior to cementing, and to determine whether the length of the prosthesis is appropriate. If the prosthesis is too long, tension will be placed on the neurovascular structures when the knee is extended. In addition, the extensor mechanism may be tight, causing a loss of flexion and difficulty in closing the soft tissues.

To determine the appropriate length, one must extend the knee and monitor the distal pulse with the trial prosthesis in place. Leg length can be further evaluated by verifying the measurement made previously between the marks made on the femur and the tibia (see **Figure 1** page 8). The extensor mechanism should also be pulled out to length with the leg in full extension to evaluate patellar position and reattachment of the patellar tendon.

Based on the trial reduction and kinematics, different thickness insert trials can be used to optimize kinematics and patellar tracking.

Rotational Alignment of the tibial trials can be optimized at this stage. Once optimal alignment is established, a mark should be made on the tibia in line with the rotational reference mark on the trial stem. (**Figure 14a**). Typically, this reference mark will not be aligned with the center of the tibial crest.

6481-1-3XX

Trial Femoral Component



MRH Instrument Tray H1

6778-6-XXX

Trial Stem



Trial Stem Tray R6

6496-2-115

Trial Axle



GMRS Tray No: 2

6496-2-13X

Trial Bumper



GMRS Tray No: 2

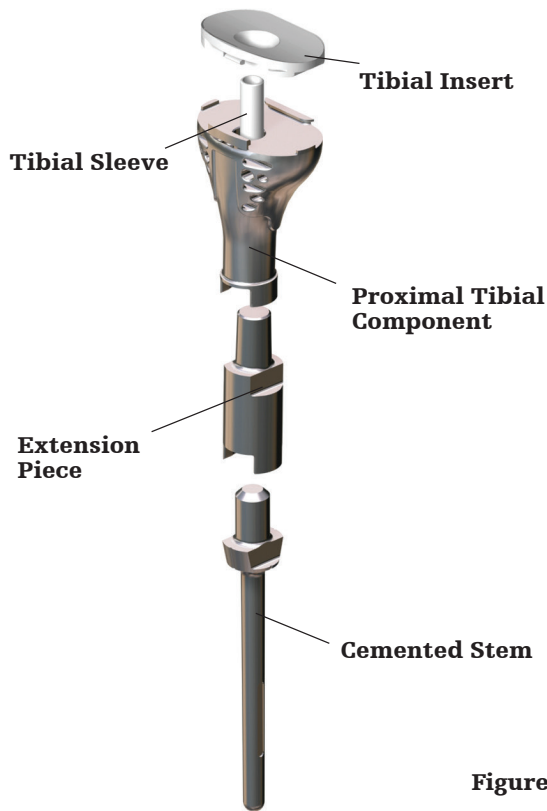

Figure 15a

Tibial implant assembly

The Proximal Tibia prosthesis consists of the cemented stem, Extension Piece (when needed based on the length of the reconstruction), the Proximal Tibia replacement, the Tibial Insert and Tibial Sleeve (**Figure 15a**). If necessary, it is acceptable to stack two Extension Pieces to construct the necessary length. The instruments used for the assembly of the prosthesis are the Impaction Tube, Impaction Tube Insert, 5-in-1 Impactor, and a Mallet.

Note: Before joining any of the tapers, make sure the male and female components are completely clean and dry.

Insert the appropriate size Impaction Tube Insert (7-11, or 13-17) into the Impaction Tube (**Figure 15b**). The selected size stem implant is inserted into the impaction tube assembly. If an Extension Piece is required, it is assembled onto the male taper of the stem, and the male taper of the Extension Piece is impacted by placing the appropriate size hole of the 5-in-1 Impactor over it and hitting with a Mallet (**Figure 15c**). The Proximal Tibial Component is then mounted onto the male taper of the Stem or Extension Piece. The 5-in-1 Impactor can be used to impact the assembly by aligning the two holes of the impactor with the two tabs of the Proximal Tibia segment and hitting with a Mallet (**Figure 15d**).

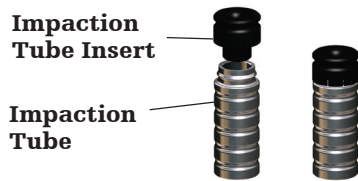

Figure 15b

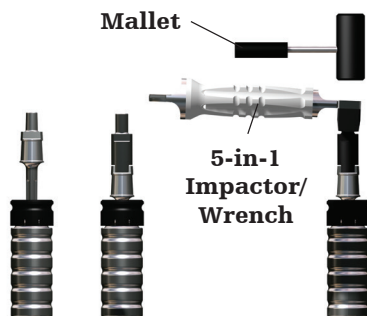

Figure 15c



Figure 15d

6496-9-06X
 Impaction Tube Insert
 GMRS Tray No: 4A



6496-9-053
 Impaction Tube
 GMRS Tray No: 4A



6496-9-063
 5-in-1 Impactor
 GMRS Tray No: 3



Femoral implant assembly

To attach a CoCr Stem to the implant, hand tighten the stem into the stem boss as far as possible. Attach the All-in-One Wrench to the Torque Wrench, insert the male hex tip of the wrench into the hex recess of the stem and tighten to 120-180 in/lbs (**Figure 16a**).

Note: If using a 155mm Titanium Fluted Stem, tighten to 120-180 in/lbs with the Tri-Fluted Section of the All-in-One Wrench (Figure 16b).

Note: Orient the All-in-One Wrench with the long axis of the Torque Wrench.

Note: A stem of at least 80mm must be used on the MRH femoral components.

The Distal Femoral Augments are attached by screw fixation to the distal condylar area of the femoral component. The Torque Wrench is attached to the Distal Locking Screw Adaptor via the 3/8" Square Drive Adaptor. A locking torque of 60-80 in/lbs is applied to the screw head in order to lock the Augment and femoral component together (**Figure 16c**).

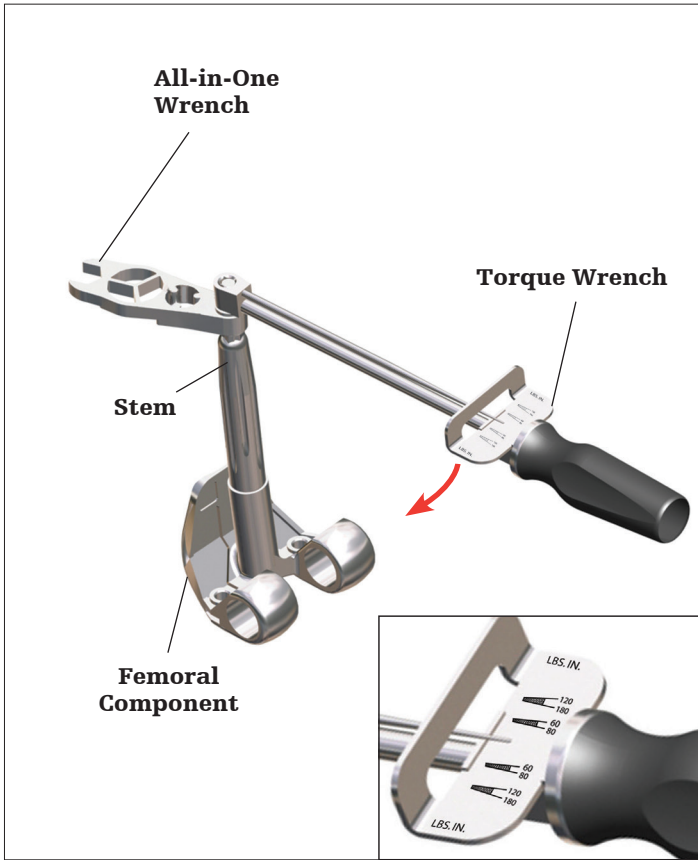

Figure 16a

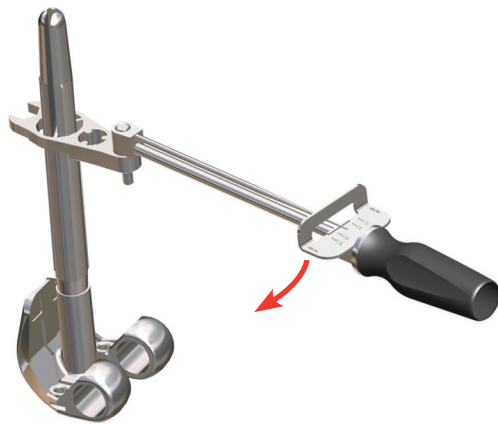

Figure 16b

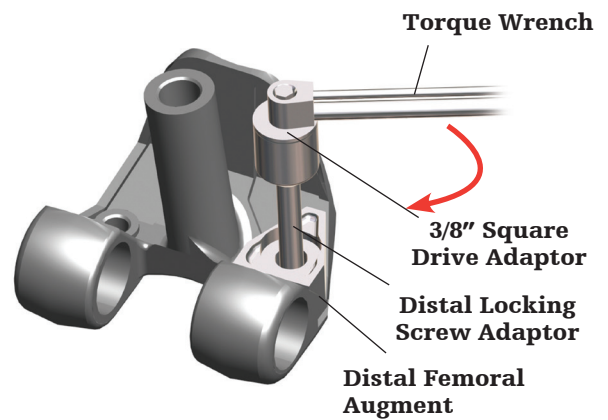

Figure 16c

8200-0105

All-in-One Wrench

MRH Instrument Tray H2



6633-9-986

Torque Wrench
MRH Instrument Tray H2



6633-8-230

Distal Locking Screw Adaptor

MRH Instrument Tray H2



6633-9-989

3/8" Square Drive Adaptor

MRH Instrument Tray H2

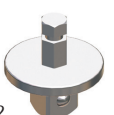

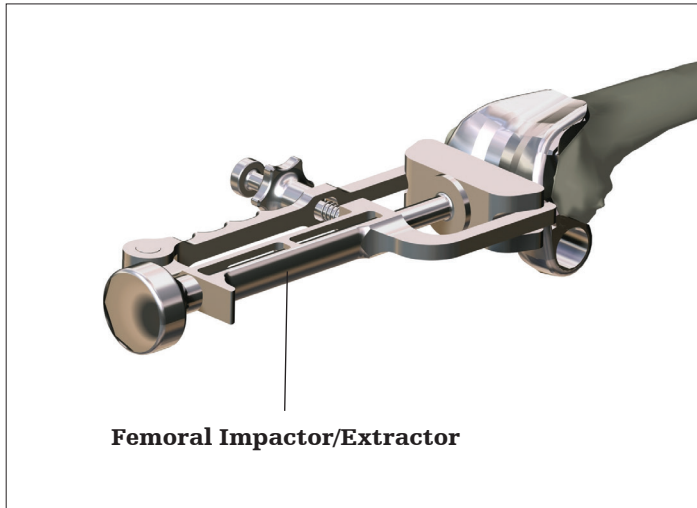

Figure 17

Implantation and orientation of the femoral and tibial prostheses

Surgical tip: If a stem centralizer is not being used, plug the hole in the stem with bone cement. Failure to plug the hole may lead to increased porosity of the cement at the stem tip, where peak stresses occur in the cement and may initiate cracks in the cement at the stem tip.

The prosthesis is then inserted into the tibial canal until the stem seat is flush with the host bone at the osteotomy site and aligned with the mark previously made on the tibia. Excess cement is removed from around the prosthesis.

Surgical bone cement is applied to the cut surfaces of the distal femur and to the inner surfaces and around the boss of the femoral implant construct. To implant the femoral component, the medullary canal is irrigated and dried. The prosthesis is attached to the Femoral Impactor/Extractor (**Figure 17**) and guided onto the femur and impacted until it is flush with the cut surfaces.

8000-8080

Femoral Impactor/
Extractor

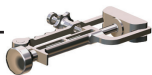

Extension Gap Prep. Tray R3

Final trial articulation with prostheses

With the femoral and tibial prostheses in place, it is possible to use the Trial Axle, the Trial Bumper, the Trial Tibial Rotating Component and the Trial Tibial Insert to verify that the appropriate motion, stability and patellar tracking will be achieved (**Figure 18**). With the knee in full extension this also assists in loading the femoral and tibial components while the cement is curing to provide an optimal bond between implant and bone.

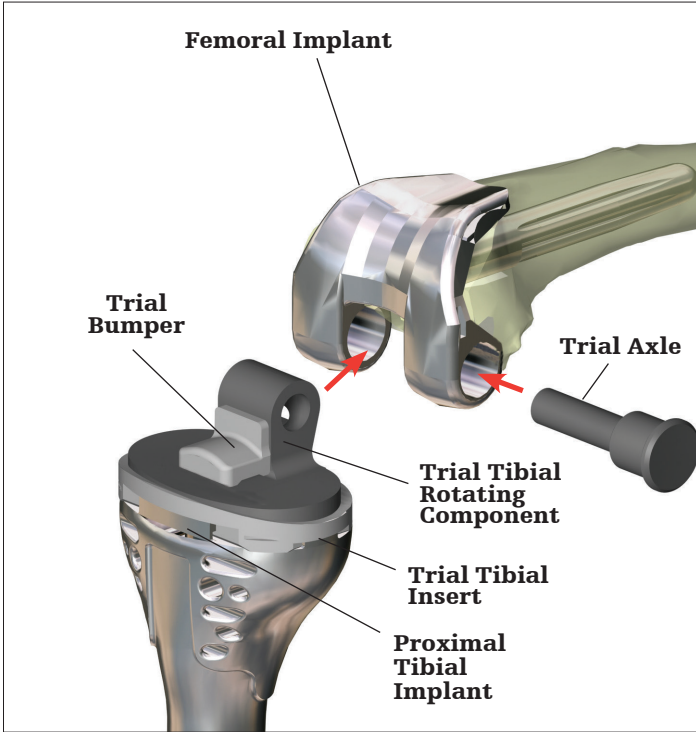

Figure 18

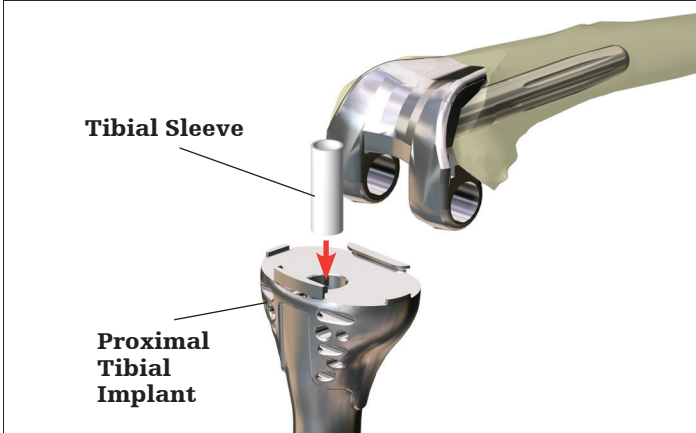

Figure 19a

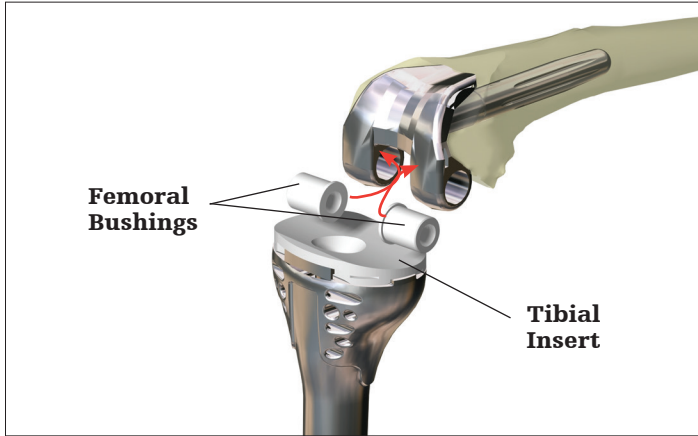

Figure 19b

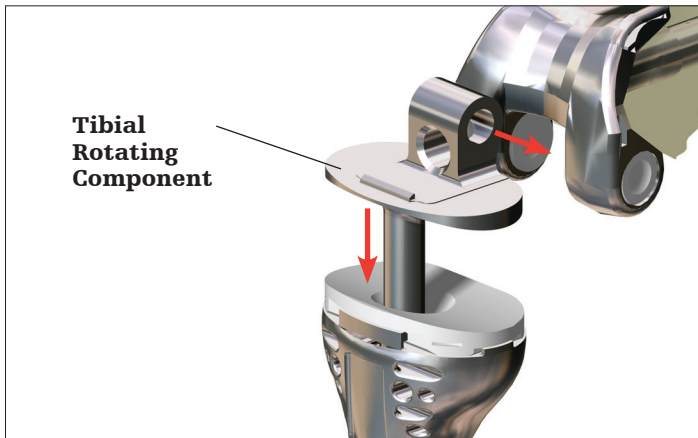

Figure 19c

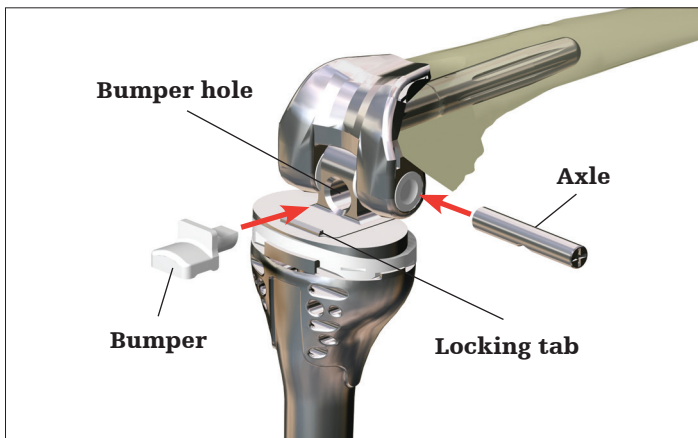

Figure 19d

The Tibial Sleeve is inserted into the Proximal Tibia (**Figure 19a**). The appropriate size Tibial Insert is impacted onto the Proximal Tibia. The two bushings are inserted into the femoral component from the centerline of the implant outward as shown (**Figure 19b**). The Tibial Rotating Component is inserted into the Proximal Tibia and brought between the bushings (**Figure 19c**). The Axle is then introduced as shown (**Figure 19e**). A recess or cut-out exists on the Axle to accept the Bumper. By viewing through the bumper hole, verify the recess of the Axle is aligned with the hole. The Bumper is then inserted as shown (**Figure 19d**) to lock the assembly together. It should be impacted until flush with the Tibial Rotating Component, and has cleared the locking tab.

Surgical tip: The Axle Guider Rod can be threaded into the end of the Axle implant to help guide and align the holes of the bushings with the hole of the TRC during assembly. The Axle Introducer can be used to rotate the Axle to align the recess in the axle with the bumper hole to assemble the bumper.

Note: After the bumper is in place, the axle should not be rotated. It will be in its final position.

Assembly of Rotating Hinge mechanism

The parts needed to assemble the Rotating Hinge mechanism are shown in **Figure 19e**.

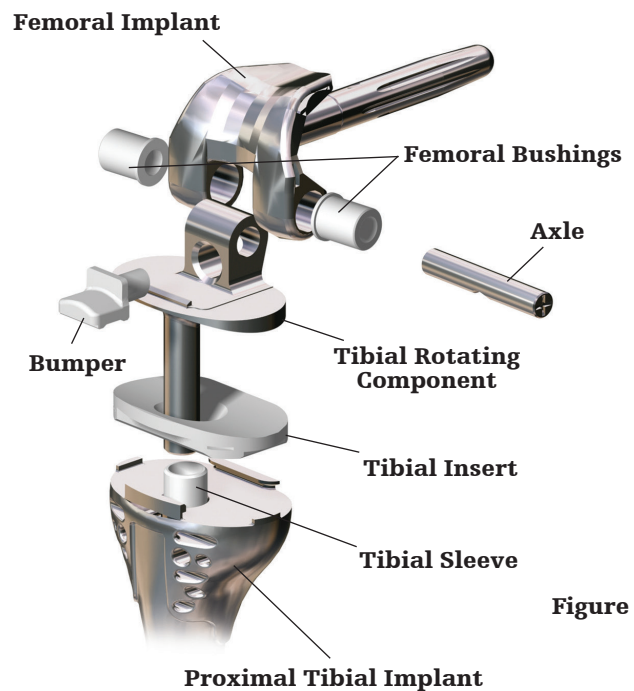

Figure 19e

6481-1-008

Axle Guider Rod



6483-9-008

Axle Introducer



MRH Instrument Tray H1

MRH Instrument Tray H1

Appendix - taper disassembly

Should it be necessary to disengage an assembled taper joint, a Taper Separator is provided. The correct orientation is in an anterior-to-posterior direction. The implants are designed to withstand the forces generated by the separator in this direction. Placement of the separator wedges against the anti-rotation tabs may damage them, making disengagement difficult. The separator may be used via three different methods.

Method 1

The wedges are initially advanced by hand to bring them in contact with the implant at the joint to be disengaged. The wedges are advanced by turning the nut in a clockwise direction, until resistance is felt (**Figure 20a**). The wedges are then further advanced, using the wrench end of the 5-in-1 Impactor provided, until the tapers disengage.

Method 2

The wedges of the separator are advanced until they are sufficiently tight against the taper junction to be separated using the wrench end of the 5-in-1 Impactor. A mallet can then be used to impact the chisel component of the separator. The separator is designed to allow the nut and chisel to travel a small distance when impacted to ease separation.

Method 3

The separator can be disassembled and the chisel component of the assembly can be used by itself to separate a taper junction (**Figure 20b**). The chisel is inserted anteriorly at the location to be separated and impacted with a mallet until separation is achieved.

Caution should be taken when disengaging any taper-locked joint. The high forces that hold a taper-locked joint together may result in a sudden and forceful action upon disengagement along the axis of the tapers.

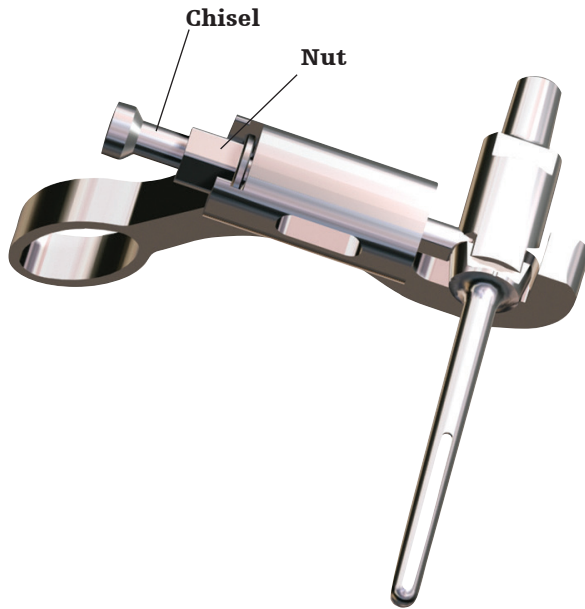

Figure 20a

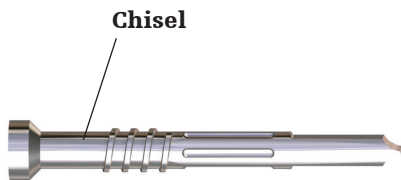

Figure 20b

6496-9-054/055/056

Taper Separator

GMRS Tray No: 3



Implant listing

Description	Diameter	Titanium Fluted		Cobalt Chrome	
		80mm	155mm	80mm	15mm
Stem	10mm	6478-6-600	6478-6-680	6478-6-395	6478-6-435
Stem	11mm	6478-6-605	6478-6-685	6478-6-396	6478-6-436
Stem	12mm	6478-6-610	6478-6-690	6478-6-397	6478-6-437
Stem	13mm	6478-6-615	6478-6-695	6478-6-398	6478-6-438
Stem	14mm	6478-6-620	6478-6-705	6478-6-399	6478-6-439
Stem	15mm	6478-6-625	6478-6-710	6478-6-400	6478-6-440
Stem	16mm	6478-6-630	6478-6-715	6478-6-405	6478-6-445
Stem	17mm	6478-6-635	6478-6-720	6478-6-410	6478-6-450
Stem	18mm	6478-6-640	6478-6-725	6478-6-415	6478-6-455
Stem	19mm	6478-6-645	6478-6-730	6478-6-420	6478-6-460
Stem	21mm	6478-6-655	6478-6-740	6478-6-425	6478-6-465
Stem	23mm	6478-6-665	6478-6-750	6478-6-430	6478-6-470
Description	Size	Left	Right	M/L	A/P
MRH Femoral Component	XS	6481-1-100	6481-1-101	60mm	54mm
MRH Femoral Component	Small	6481-1-110	6481-1-111	65mm	55mm
MRH Femoral Component	Medium	6481-1-120	6481-1-121	70mm	61mm
MRH Femoral Component	Large	6481-1-130	6481-1-131	75mm	64mm
MRH Femoral Component	XL	6481-1-140	6481-1-141	80mm	66mm
Description	Size	Ref #			
Femoral Distal Block 10mm	XS	6481-1-200			
Femoral Distal Block 10mm	Small	6481-1-210			
Femoral Distal Block 10mm	Medium	6481-1-220			
Femoral Distal Block 10mm	Large	6481-1-230			
Femoral Distal Block 10mm	XL	6481-1-240			
Description	Size	Ref #			
MRH Axle	All Sizes	6481-2-120			
MRH Femoral Bushing	All Sizes	6481-2-110			
Tibial Sleeve	All Sizes	6481-2-140			
Bumper Insert	Neutral	6481-2-130			
Bumper Insert	3 Degrees	6481-2-133			
Description	Size	Ref #			
GMRS Tibial Rotating Component for Small Proximal Tibia only	Small	6495-3-601			
MRH Tibial Rotating Component for Standard Proximal Tibia only	Standard	6481-2-100			
Description	Thickness	Ref #			
GMRS Tibial Insert for Small Proximal Tibia	10mm	6495-3-010			
GMRS Tibial Insert for Small Proximal Tibia	13mm	6495-3-013			
GMRS Tibial Insert for Small Proximal Tibia	16mm	6495-3-016			
GMRS Tibial Insert for Small Proximal Tibia	20mm	6495-3-020			
GMRS Tibial Insert for Small Proximal Tibia	24mm	6495-3-024			
Description	Thickness	Ref # S1/S2			
MRH Tibial Insert for Standard Proximal Tibia	10mm	6481-3-210			
MRH Tibial Insert for Standard Proximal Tibia	13mm	6481-3-213			
MRH Tibial Insert for Standard Proximal Tibia	16mm	6481-3-216			
MRH Tibial Insert for Standard Proximal Tibia	20mm	6481-3-220			
MRH Tibial Insert for Standard Proximal Tibia	24mm	6481-3-224			

Description	Size	Ref #	M/L	A/P
Proximal Tibial Component	Small	6495-3-101	52mm	41mm
Proximal Tibial Component	Standard	6495-3-102	65mm	54mm

Description	Length	Ref #
Extension Piece	30mm	6495-6-030
Extension Piece	40mm	6495-6-040
Extension Piece	50mm	6495-6-050
Extension Piece	60mm	6495-6-060
Extension Piece	70mm	6495-6-070
Extension Piece	80mm	6495-6-080

Description	Diameter	Straight stem	
		With porous coated body section	Without porous coated body section
Cemented Stem (102mm Length)	8mm	6485-3-008	6485-3-018
Cemented Stem (102mm Length)	9mm	6485-3-009	6485-3-019
Cemented Stem (102mm Length)	10mm	6485-3-000	6485-3-010
Cemented Stem (127mm Length)	11mm	6485-3-011	6485-3-111
Cemented Stem (127mm Length)	13mm	6485-3-013	6485-3-113
Cemented Stem (127mm Length)	15mm	6485-3-015	6485-3-115
Cemented Stem (127mm Length)	17mm	6485-3-017	6485-3-117

Resection length chart

Proximal Tibial Component length (including 10mm Tibial Insert) = 80mm
Tibial Rotating Component = 8mm
Stem without body = 11mm
Stem with body = 40mm

Extension Piece length	Stem without body	Stem with body
None	99mm	128mm
30mm	129mm	158mm
40mm	139mm	168mm
50mm	149mm	178mm
60mm	159mm	188mm
70mm	169mm	198mm
80mm	179mm	208mm

GMRS Proximal Tibia surgical protocol

Notes

Notes

Joint Replacement

This document is intended solely for the use of healthcare professionals.

GMRS Proximal Tibial components are marketed in the United States for use with bone cement.

A surgeon must always rely on his or her own professional clinical judgment when deciding whether to use a particular product when treating a particular patient. Stryker does not dispense medical advice and recommends that surgeons be trained in the use of any particular product before using it in surgery.

The information presented is intended to demonstrate the breadth of Stryker's product offerings. A surgeon must always refer to the package insert, product label and/or instructions for use before using any Stryker product. The products depicted are CE marked according to the Medical Device Directive 93/42/EEC. Products may not be available in all markets because product availability is subject to the regulatory and/or medical practices in individual markets. Please contact your Stryker representative if you have questions about the availability of Stryker products in your area.

Stryker Corporation or its divisions or other corporate affiliated entities own, use or have applied for the following trademarks or service marks: GMRS, Duracon, Stryker, Stryker Orthopaedics. All other trademarks are trademarks of their respective owners or holders.